

MAX FRESH

USECO
735 FLORENCE RD
SAVANNAH, TN 38372
1-800-251-3398

OPERATION MANUAL

FT SERIES
FROST TOPS

FT MODELS

FT-7200SL	FT-1
FT-7300SL	FT-2
FT-7400SL	FT-3
	FT-4
	FT-5
	FT-6

INCLUDES (SL) SLIM LINE UNITS

INCLUDES
INSTALLATION
USE & CARE

IMPORTANT: DO NOT DISCARD THIS MANUAL

This manual is considered to be a part of the appliance and is to be given to the OWNER or MANAGER of the restaurant, or to the person responsible for TRAINING OPERATORS of this appliance. Additional manuals are available from your USECO dealer.

THIS MANUAL MUST BE READ AND UNDERSTOOD BY ALL PERSONS USING OR INSTALLING THIS APPLIANCE. Contact your USECO DEALER if you have any questions concerning installation, operation or maintenance of this equipment.

LIMITED WARRANTY STATEMENT

USECO equipment is warranted to be free of defects in material and workmanship for a period of 12 months from the date of shipment from the factory. Warranty applies to the contiguous 48 states, to the original commercial end user and is not transferable.

Warranty applies only to properly installed equipment under conditions of normal use in standard commercial foodservice operations and receiving proper preventative maintenance. Normal wear & tear is not covered.

Warranty does not apply to failure from poor or inadequate water supply, improper cleaning, exposure to corrosive and harsh chemicals or acids and does not apply to defects from misuse, neglect, improper installation, freight damage or accidents, fire, flood, riot or acts of God.

USECO's warranty does not include any coverage for loss of business, loss of use, loss of time, loss of profits or income, loss of food products or labor cost and is limited to USECO manufactured products and does not apply to equipment connected to or installed with USECO products.

Enough access must be available for service technicians to adequately service equipment. Equipment built into cabinets, tables or structures by others with insufficient access is not covered under labor warranty

Warranty is void if the equipment has been modified, if parts have been substituted, if the name/ model plate is missing or has been defaced or if the equipment has been repaired or altered by anyone other than an authorized USECO agent.

Warranty work must be authorized in advance by the USECO factory. Claims for work performed without pre-authorization are subject to rejection. For warranty authorization call USECO technical service department at 800-251-3398. A service technician will diagnose, and trouble shoot with the end user to find a service solution. If a solution can not be resolved over the phone, USECO will determine how best to resolve the issue, which may include dispatching a service agent, shipping a part or another method to provide a solution.

When calling USECO for warranty service please have the following information ready: name and address of business location, contact information, model and serial number, date of purchase, name of dealer where purchased, credit card information and a description of the service issue.

Warranty covers parts and labor performed during normal business hours. Labor performed after hours, on weekends or holidays are not covered and are at the discretion and expense of the end user and not paid by USECO. Travel mileage is covered up to 100 miles round trip or up to 2 hours round trip. Additional time and travel will be at the end users' expense.

USECO's sole obligation is to repair or replace the product at USECO's option. This warranty is in lieu of all other warranties expressed or implied, including any warranty of merchantability, and fitness for a particular purpose

SERVICE POLICY AND PROCEDURE GUIDE ADDITIONAL WARRANTY EXCLUSIONS

1. Resetting of safety thermostats, circuit breakers, overload protectors, and/ or fuse replacement are **not** covered by this warranty unless warranted conditions are the cause.
2. All problems due to operation at **voltages or phase other than specified on equipment nameplates are not covered by this warranty.** Conversion to correct voltage and/or phase must be the customer's responsibility.
3. All problems due to **electrical connections not made in accordance with electrical code requirements and wiring diagrams** supplied with the equipment are not covered by this warranty.
4. Replacement of items **subject to normal wear**, to include such items as knobs, light bulbs, and normal maintenance functions including adjustments of micro switches and replacement of fuses and indicating lights are **not** covered by warranty.
5. Damage to electrical cords and/or plug due to exposure to excessive heat are **not** covered by this warranty.
6. Full use, care, and maintenance instructions supplied with each machine. Noted maintenance and preventive maintenance items, such as servicing and cleaning schedules, is customer responsibility. Those miscellaneous adjustments noted are customer responsibility. Proper attention to preventive maintenance and scheduled maintenance procedures will prolong the life of the appliance.
7. Travel mileage is limited to **sixty (60) miles** from an Authorized Service Agency or one of its sub-service agencies.
8. All labor shall be performed during regular working hours. Overtime premium will be charged to the buyer.
9. All genuine AFC replacement parts are warranted for ninety (90) days from date of purchase on non-warranty equipment. This parts warranty is limited only to replacement of the defective part(s). **Any use of non-genuine AFC parts completely voids any warranty.**
10. Installation, labor, and job checkouts are **not** considered warranty and are thus **not** covered by this warranty.
11. Charges incurred by delays, waiting time or operating restrictions that hinder the service technician's ability to perform service are **not** covered by warranty. This includes institutional and correctional facilities.

SHIPPING DAMAGE CLAIM PROCEDURE

NOTE: For your protection, please note that equipment in this shipment was carefully inspected and packaged by skilled personnel before leaving the factory. Upon acceptance of this shipment, the transportation company assumes fully responsibility for its safe delivery. **IF SHIPMENT ARRIVES DAMAGED:**

1. **VISIBLE LOSS OR DAMAGE:** Be certain that any visible loss or damage is noted on the freight bill or express receipt, and that the note of loss or damage is signed by the delivery person.
2. **FILE CLAIM FOR DAMAGE IMMEDIATELY:** Regardless of the extent of the damage.
3. **CONCEALED LOSS OR DAMAGE:** If damage is unnoticed until the merchandise is unpacked, notify the transportation company or carrier immediately, and file "CONCEALED DAMAGE" claim with them. This should be done within fifteen (15) days from the date the delivery was made to you. Be sure to retain the container for inspection.

USECO cannot assume liability for damage loss incurred in transit. We will, however, at your request, supply you with the necessary documents to support your claim.

INTRODUCTION

Thank you for purchasing this USECO appliance.

Proper installation, professional operation and consistent maintenance of this appliance will ensure that it gives you the very best performance and a long, economical service life.

This manual contains the information needed to properly install this appliance, and to use and care for the appliance in a manner which will ensure its optimum performance.

ELECTRICAL & REFRIGERATION SPECIFICATIONS

CORD-CONNECTED MODELS

MODELS	FT-1, FT-2 FT-7200SL	FT-3 FT-7300SL	FT-4 FT7400SL
VOLTAGE	115 VAC 60 Hz.	115 VAC 60 Hz.	115 VAC 60 Hz.
TOTAL AMPS	5.3 A	7.0 A	7.5 A
REFRIGERANT (AMOUNT / TYPE)	28 oz. / R-134A	24 oz. / R-404A	32 oz. / R-404A
PRESSURE (High Side / Low Side)	440 / 162 psig	500 / 174 psig	500 / 174 psig

PERMANENTLY CONNECTED MODELS

MODELS	FT-5, FT-6
SINGLE PHASE VOLTAGE	115 VAC 60 Hz.
TOTAL AMPS	15.3 A
MCA / MES / LRA	21.0A / 30A / 59A
REFRIGERANT (Amount / Type)	54 oz. / R-404A
PRESSURE (High Side / Low Side)	500 / 174 psig

FEATURES & OPERATING CONTROLS

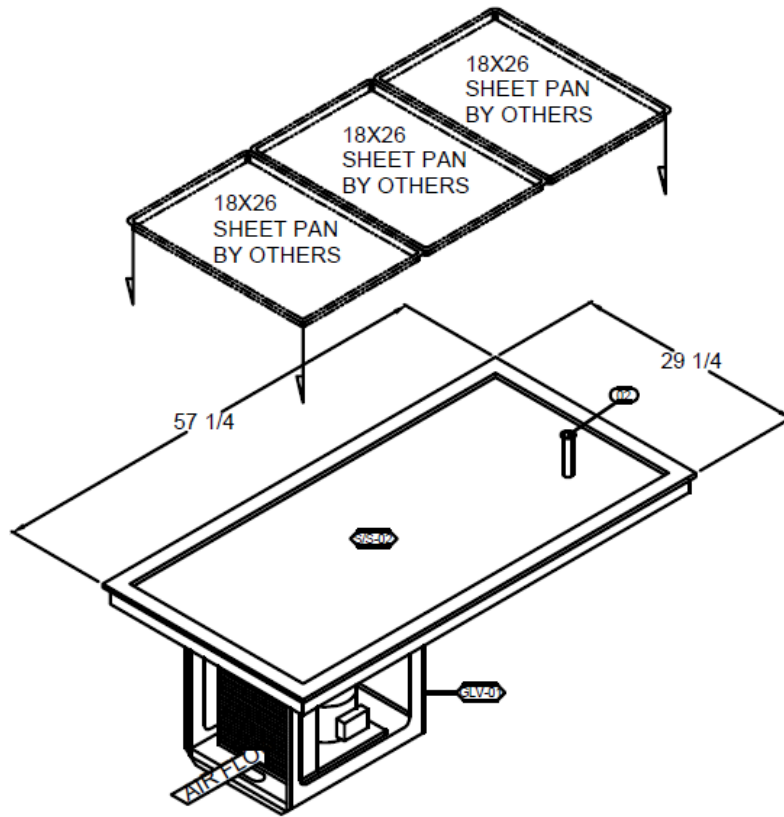

NOTE:

This is a general arrangement drawing only. Actual component positions may vary between units.

PRECAUTIONS & GENERAL INFORMATION

This appliance is intended for use in commercial establishments only and is intended to hold pre-chilled prepared food for human consumption. No other use is recommended or authorized by the manufacturer or its agents.

Operators of this appliance must be familiar with the appliance use, limitations and associated restrictions. Operating instructions must be read and understood by all persons using this appliance.

Food must be kept in appropriate inserts. Never place food directly into the tank.

Cleanliness of this appliance is essential to good sanitation. Read and follow all included cleaning instructions and schedules to ensure the safety of the food product.

Disconnect this appliance from electrical power before performing any maintenance or servicing.

This appliance is not jet stream approved. Do not direct water jet or steam jet at this appliance, or at any control panel or wiring. Do not splash or pour water on, in or over any controls, control panel or wiring. Do not wash floor around this appliance with water or steam jet.

The technical content of this manual, including any wiring diagrams, schematics, parts breakdown illustration and/or adjustment procedures, is intended for use by qualified technical personnel.

Any procedure, which requires the use of tools, must be performed by a qualified technician.

This manual is considered to be a permanent part of the appliance. This manual and all supplied instructions, diagrams, schematics, parts breakdown illustration, notices and labels must remain with the appliance if it is sold or moved to another location.

This appliance is made in the USA. Unless otherwise noted, this appliance has American sizes on all hardware.

WARNING:

ELECTRIC SHOCK HAZARD

All servicing requiring access to non-insulated electrical components must be performed by a factory authorized technician. **DO NOT** open any access panel which requires the use of tools. Failure to follow this warning can result in severe electrical shock.

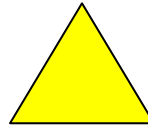

CAUTION:

RISK OF DAMAGE

DO NOT connect or energize this appliance until all installation instructions are read and followed. Damage to the appliance will result if these instructions are not followed.

AGENCY LISTING INFORMATION

Models FT-1 thru FT-6 and FT7200SL-FT7400SL have been evaluated by NSF International for sanitation requirements and not performance tested for potentially hazardous foods.



FT units are Underwriters Laboratory listed.



INSTALLATION

NOTE: DO NOT discard the carton or other packing materials until you have inspected the appliance for hidden damage and tested it for proper operation. Refer to: *SHIPPING DAMAGE CLAIM PROCEDURE* on the inside of this manual.

WARNING:
RISK OF PERSONAL INJURY
Installation procedures must be performed by a qualified technician with full knowledge of all applicable electrical and plumbing codes. Failure can result in personal injury and property damage.

IMPORTANT:
Unit must remain in an upright position during installation to prevent damage to the refrigeration system.

IMPORTANT:
Refrigeration system is air-cooled. Recommended louvered grills or equivalent openings front and rear, each with a minimum size of twice the surface area of the condenser, to provide adequate air circulation.

IMPORTANT:
Access is required for the operation of the drain valve and for maintenance of the refrigeration unit. Provide adequate access to the drain valve and refrigeration unit.

IMPORTANT:
Unit flange must be sealed to the countertop. Damage caused by leaks due to improper installation is NOT covered by warranty.

UNPACKING & INSPECTION

Carefully remove the appliance from the carton. Remove all protective plastic film, packing materials and accessories from the appliance before connecting electrical power or otherwise performing any installation procedure.

Carefully read all instructions in this manual and the *Installation Instruction Sheet* packed with the appliance before starting any installation.

Read and understand all labels and diagrams attached to the appliance.

USECO units must remain upright at all times (shipping & installation) to prevent damage to the condensing unit. If the unit is accidentally tipped, allow unit to sit upright for at least 24 hours before connecting to electric power.

PREPARATION

Cutout dimensions for tank units and control panels are listed on the *Installation Instructions* provided with the unit.

Provide at least 1" clearance around the condensing unit chassis.

Countertop must be flat and level before the unit is installed. After cutout is made, add stiffeners or bottom braces to counter as required to support unit weight.

IMPORTANT:
Refrigeration system is air-cooled. Recommend louvered grills or equivalent opening front and rear, each with a minimum size of twice surface area of the condenser, to provide adequate air circulation.

NOTE: The condenser fan is provided with a fan guard. DO NOT remove the condenser fan guard.

Provide louvered grills and service access below control panel.

Provide access to the POWER SWITCH and TEMP CONTROL UNIT located at the front of the condenser.

Verify that provided sealants are applied to the underside of the top flange prior to setting the unit into the cutout.

After installation, apply a thin bead of food-grade silicone sealant around the flange to seal it to the counter.

Avoid storing flammable or combustible materials in, on or near the appliance.

INSTALLATION (continued)

ELECTRICAL INSTALLATION

1. Refer to the nameplate. Verify the electrical service power. Voltage and phase must match the nameplate specifications. Wiring the unit to the wrong voltage can severely damage the unit or cause noticeably decreased performance.
2. Available electrical service amperage must meet or exceed the specifications listed on the specification sheet provided with the unit.
 - a. Cord-connected units are equipped with a three-prong (grounding) plug for your protection against electric shock. This must be plugged into a properly grounded matching receptacle.

PLUMBING INSTALLATION

1. Plumb connections must be made in Compliance with all Federal, State and Local Plumbing Codes and Ordinances.

IMPORTANT: All drain plumbing must be performed by a qualified plumber.
2. Install provided 1” drain valve on unit drain. Plumb to an appropriate waste as required by local plumbing and sanitation ordinances.

WARNING:

Electric Shock Hazard

All servicing requiring access to non-insulated electrical components must be performed by a factory-authorized technician. **DO NOT** open any access panel that requires the use of tools. Failure to follow this warning can result in severe electrical shock.

CAUTION:

Risk of Damage

DO NOT connect or energize this appliance until all installation instructions are read and followed. Damage to the appliance will result if these instructions are not followed.

CAUTION:

Electrical Shock Hazard

Cord-connected units are equipped with a three-prong plug for your protection against electrical shock. Never cut the large round prong from the plug, or twist a blade to fit an existing receptacle.

IMPORTANT:

Contact a licensed electrician to install the correct circuit and receptacle.

OPERATION

CAUTION: Electrical Shock Hazard

DO NOT splash or pour water onto control panel or wiring.

FT units are designed to hold REFRIGERATED PRE-CHILLED products at serving temperature.

FT units should not be used to chill product, or to hold product for long-term storage.

OPERATION NOTES

1. Never place food directly on frosted top. Always use inserts or food pans.
2. Use only pre-chilled products. Stir product occasionally to maintain chilled temperatures and prevent bottom freezing.
3. Periodically clean condensing coils to remove accumulated dust and debris. Failure to clean coils will decrease performance and may void the warranty. See *CONDENSER CLEANING*, page 8.

DAILY START-UP

1. Turn POWER SWITCH (located on condensing unit) *ON*. Allow unit to run for approximately 30 minutes to reach operating temperature.
2. Install appropriate food pans or inserts. Place pre-chilled product on frosted top.

DAILY SHUT-DOWN

1. Turn POWER SWITCH *OFF*. Remove product.
2. Allow unit to defrost before cleaning. See *CLEANING INSTRUCTIONS*, page 7

CLEANING INSTRUCTIONS

PREPARATIONS: TURN POWER SWITCH *OFF*.
Unplug unit or disconnect from
electric power. Allow unit to
defrost before proceeding.
Remove any inserts, pans and/or
adapter tops (if used).

CAUTION:
Electrical Shock Hazard

DO NOT splash or pour water
onto control panel or wiring.

FREQUENCY: Daily

TOOLS: Warm Water and Mild Detergent
Solution: 10 Parts Warm Water
 to 4 Parts Vinegar
Plastic Scouring Pad
Clean Cloth or Sponge
Food-Grade Silicone Sealant

IMPORTANT: DO NOT USE STEEL WOOL FOR CLEANING.

1. Allow unit to defrost. Wipe surfaces of frost top using a clean cloth or sponge and mild detergent.
2. Use a plastic scouring pad to remove any mineral deposits.
3. Rinse top thoroughly with a vinegar and water solution to neutralize all detergent or cleanser residue.
4. Check drain screen, clean if necessary and reinstall.
5. Periodically inspect frost top flange-to-counter seal. Reseal with food-grade silicone sealant if necessary.
6. Inspect condenser. Clean if required.
7. Inspect cooling louvers in counter. Remove any lint or debris.
8. Reconnect to electric power. Turn POWER SWITCH *ON* when unit is to be used.

Procedure is complete.

CAUTION:
Personal Injury Hazard

Disconnect appliance from electrical power before cleaning condenser coil.

CAUTION:
Personal Injury Hazard

Condenser coil fins are sharp. Use care to avoid cuts while cleaning the condenser.

CONDENSER COIL CLEANING INSTRUCTIONS

The condenser coil must be kept clean to allow adequate air flow for proper heat dissipation. Recommend this procedure be performed monthly.

1. Turn POWER SWITCH *OFF*. Disconnect unit from electrical power.
2. Remove louvers or access panel to allow coil to be reached.
3. Using a stiff bristle brush, brush lint and debris from the condenser fins. Brush vertically, top to bottom. Collect and discard all lint and debris gathered from this operation.

IMPORTANT: The fins of the condenser are delicate and easily damaged. Use care to brush in a vertical motion to avoid damaging the coil fins.

4. Wipe the fan blades to remove accumulated lint.
5. Reconnect to electrical power. Test for proper operation.

MAINTENANCE INSTRUCTIONS (continued)

CARE OF STAINLESS STEEL

1. The surface can be damaged by mechanical abrasion, hard water deposits and chlorine:
 - a. **Never** use steel wool, wire brushes or metal scrapers to clean the appliance. These will damage the surface.
 - b. Hard water deposits left behind when water is evaporated will attack the surface and allow the stainless steel to rust.
 - c. Chlorides from chlorinated cleansers, calcium / lime / rust removers (e.g. muriatic acid), even heavily chlorinated city water will attack the surface and allow the stainless steel to rust.
 - d. **DO NOT** use any highly caustic cleaners. Use of highly caustic cleaners will damage the surface.
 - e. **LIMIT USE** of strong caustic on warmers. Rinse thoroughly with a vinegar and water solution to neutralize any residue. Failure to do so may cause damage to the surface and allow the stainless steel to rust.
 - f. Cleaners containing ammonia will attack the surface and allow the stainless steel to rust.
2. Use the proper tools in the proper way to clean your USECO warmer:
 - a. Soft cloth and plastic scouring pads are safe to use on stainless steel surface.
 - b. Stainless steel pads may be used **ONLY IF** the scrubbing motion is in the direction of the visible grain. **DO NOT** use a circular motion.
 - c. In the absence of visible grain, use only cloth or plastic pads. Scrub only in a linear motion along the longest axis of the equipment.
3. Use only non-chloride and non-ammonia cleansers:
 - a. **DO NOT** use any cleanser listed as “chlorinated”.
 - b. **DO NOT** use any cleanser listing “ammonia” or “ammonium” in its contents.
 - c. Contact your cleaning materials supplier for suitable alkaline cleansers.
4. Keep your USECO hot and cold pan clean. Clean frequently to avoid build-up of hard, stubborn stains and hard-to-remove deposits.
 - a. Rinse thoroughly with a vinegar and water solution to neutralize any residue.
 - b. For discoloration caused by using the warmer in dry operation, use a cleaner made specifically for stainless steel.
 - c. Wipe dry with a soft, clean dry cloth
 - d. Restore the surface by using a polishing product specifically made for stainless steel after each cleaning.
5. In areas where tap water has a high mineral content, warmers may develop lime deposits. Use a non-chloride de-liming agent to remove lime deposits. It is important to use *Lime and Scale for Warmer Pans* often to prevent a difficult-to-remove build-up of lime deposits.

CAUTION: **Personal Injury Hazard**

Disconnect appliance from electrical power before cleaning.

USECO Frost Tops are constructed of high quality stainless steel. As long as the stainless steel surface is intact, the equipment will not rust or corrode.

Recommendation:
A water softening device or a cartridge-type filtration device may be used to minimize lime and calcium build-up.

MAINTENANCE INSTRUCTIONS (continued)

IMPORTANT:

DO NOT adjust the differential settings of the refrigeration system. Field adjustments of the differential settings must be made by qualified refrigeration personnel only. Unauthorized adjustments of the differential settings will void the warranty.

The temperature setting of the frost top has been pre-set at the factory to meet most applications. An electronic temperature control allows a layer of frost to form on the top surface of the unit

TEMPERATURE ADJUSTMENT

1. The temperature has been preset at the factory to meet most applications.
2. If temperature adjustments are required, the pressure switch, located on the condensing unit, is adjustable. Temperature adjustment must be performed by a qualified refrigeration personnel only.
3. Normal temperature setting would be 1°F +/- 3°

The LCD Display provides a readout of the sensor temperature during normal operation. Use the following to change the set point temperature:

1. To start programming, press **SET** key once. This will access the Fahrenheit/ Celsius mode. The readout will show the current status, either **F** (degrees Fahrenheit) or **C** (degrees Celsius). Press either "up arrow" or "down arrow" to toggle between **F** and **C** designation.
2. Press **SET** again to access the setpoint. The LCD will display the current setpoint, and the S1 annunciator will blink off and on to indicate that control is in the setpoint mode. Press either "up arrow" to increase the setpoint, or "down arrow" to decrease the setpoint to the desired temperature. Factory setpoint is 0°F.

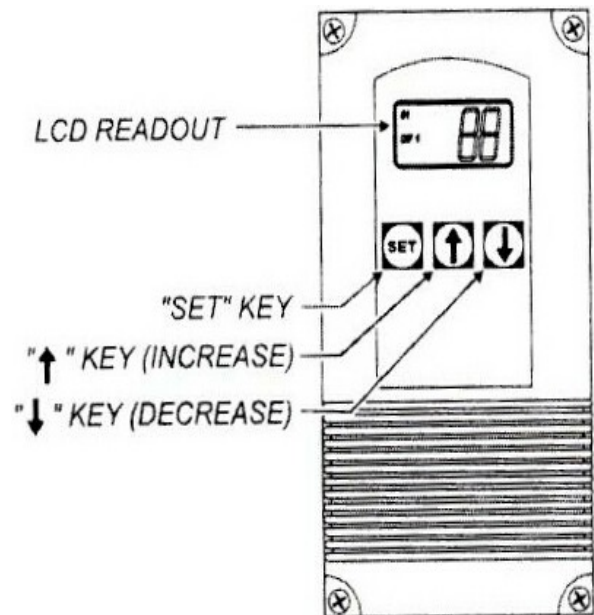

MAINTENANCE INSTRUCTIONS (continued)

3. Press the **SET** key again to access the differential. The LCD will display the current differential, and the DIF1 annunciator will blink off and on to indicate that control is in the differential mode.

IMPORTANT: DO NOT adjust the differential settings of the refrigeration system. Field adjustments of the differential settings must be made by qualified refrigeration personnel only. Unauthorized adjustment of the differential settings will void the warranty.

Press either “up arrow” to increase the differential, or “down arrow” to decrease the differential to the desired setting. Factory differential is 3°F.

4. Press the **SET** key again to access the Heating / Cooling mode. The LCD will display the current mode. Either “C1” for cooling or “H1” for heating. The control must be set to C1 for proper operation of the cold pan.
5. Press the **SET** key again to complete programming. Programming ends automatically if no keys are pressed for 30 seconds. Any settings that have been input to the control will be accepted at that time.
6. Control settings are stored in non-volatile memory. Loss of power to the unit will not require reprogramming.

IMPORTANT: DO NOT adjust the differential settings of the refrigeration system. Field adjustments of the differential settings must be made by qualified refrigeration personnel only. Unauthorized adjustment of the differential settings will void the warranty.

TROUBLESHOOTING SUGGESTIONS

SYMPTOM	POSSIBLE CAUSE	REMEDY
No power to unit	Circuit breaker tripped	Reset circuit breaker
	Power switch OFF	Turn power switch ON
Food not kept cold enough	Food not chilled to start	Add only pre-chilled food
	Food too thick	Stir thick food frequently
	Setpoint too high	Set to desired temperature
	Condenser cooling louvers or coil plugged	Clean condenser louvers and/ or coil
	Refrigerant level low	Contact Authorized USECO Service Agency for repairs
	Internal damage	Contact Authorized USECO Service Agency for repairs

PARTS & SERVICE

DESCRIPTION

PART NO.

**THERE ARE NO COMPONENTS
AVAILABLE FOR FROST TOP UNITS**

IMPORTANT: Use only factory authorized service parts and replacement filters.
For factory authorized service, or to order factory authorized replacement part, contact
your USECO authorized service agency or call:

USECO
735 Florence Rd
Savannah, TN 38372
1-800-251-3398

CUSTOMER SERVICE DATA

Please have this information available if calling for service

RESTAURANT _____ LOCATION _____

INSTALLATION DATE _____ TECHNICIAN _____

SERVICE COMPANY _____

ADDRESS _____ STATE _____ ZIP _____

TELEPHONE NUMBER (____) _____ - _____

EQUIPMENT MODEL NO. _____

EQUIPMENT SERIAL NO. _____

VOLTAGE: (check one) [] 115 [] 220 _____ 13

USECO
735 Florence Rd
Savannah, TN 38372
1-800-251-3398

